

Section 1 — Introduction

About This Manual...

This manual provides instruction for the operation of the stage. The operator must become familiar with the stage and its capabilities before operating the stage. Operator training by and authorized representative of StagePro is a requirement for operation of this equipment. This manual provides a written explanation of the operation of the stage including its proper set-up, operation, and safety procedures.

In addition to the text, there are charts and figures for additional clarification.

Throughout the manual, the term stage is used to describe the StagePro Hydraulic Stage and its subsystems. Additional copies of this manual may be obtained from StagePro. Provide your stage serial number when requesting additional manuals.

The following symbol is used throughout this manual to indicate danger, warning, and caution instructions. These instructions must be followed to reduce the likelihood of personal injury and/or property damage.



This manual identifies many of the common hazards associated with this stage, but not all hazards can be anticipated.

Section 2 — Unit Specifications

Purpose of the Stage

This 50 x 40 Hydraulic Stage has been designed and constructed to provide a transportable stage to be used for temporary venues.

An out and down outrigger system provides for the stability of the deployed stage, the tower system provides for raising and lower the roof, the roof tilt system is used to move the primary roof from vertical to horizontal and to deploy the secondary roof; and the floor system is used to take the folded floor from vertical to the horizontal position.

General Specifications

The Stage consists of four distinct hydraulic systems that are designed for depolyment of the stage from the travel condition to the fully deployed stage and back to the travel condition.

Item	Specification
Travel height	13' 3"
Overall width	102'
Total trailer weight	55,165 lbs
Distance to front trailer axle from kingpin	29' 11"
Distance to rear trailer axle from front trailer axle	10' 1"
Hydraulic pump engine	20 HP
Hydraulic pump capacity	3.0 GPM
Hydraulic pump max pressure, continuous	4,000 psi
Hydraulic pump max pressure, intermitent	4,400 psi
Hydraulic oil reservoir capacity	40 gallon
Hydraulic fluid	Hydra 1000 R&OA/A.W., ISO #32
Deployed stage length and width	50' X 38'
Deployed roof length and width	53' X 38'
Maximum deployed stage height	80'
Maximum outrigger extension	27'
Outrigger spread	20'
Maximum height from stage floor to bottom of center truss	35' 4"
Intermediate height from stage floor to bottom of center truss	25' 4"
Total number of adjustable floor leveling speed jacks	40

Figure 2.1 — Stage Specifications

Component Identification

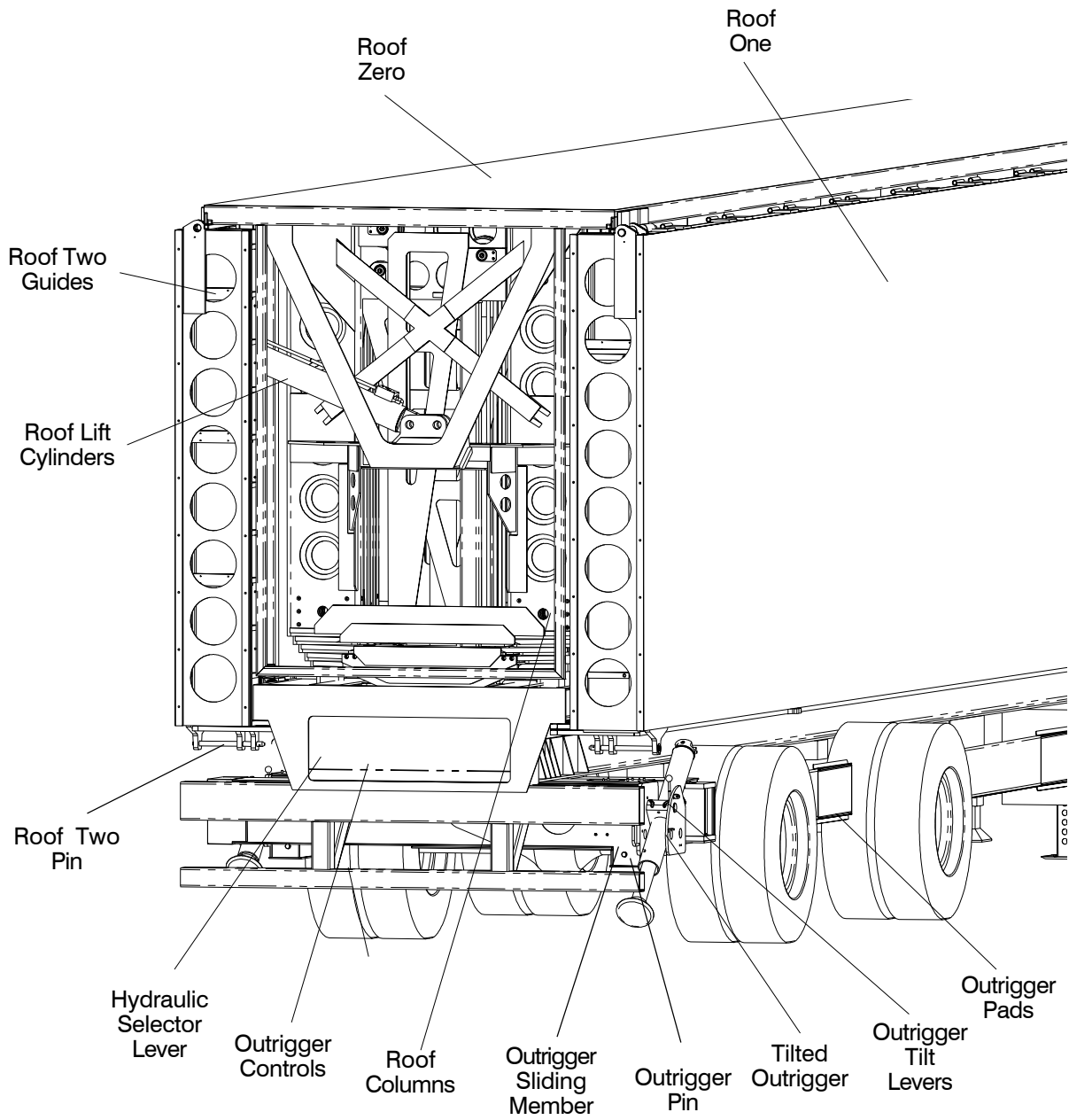

Rear View, Stowed for Travel

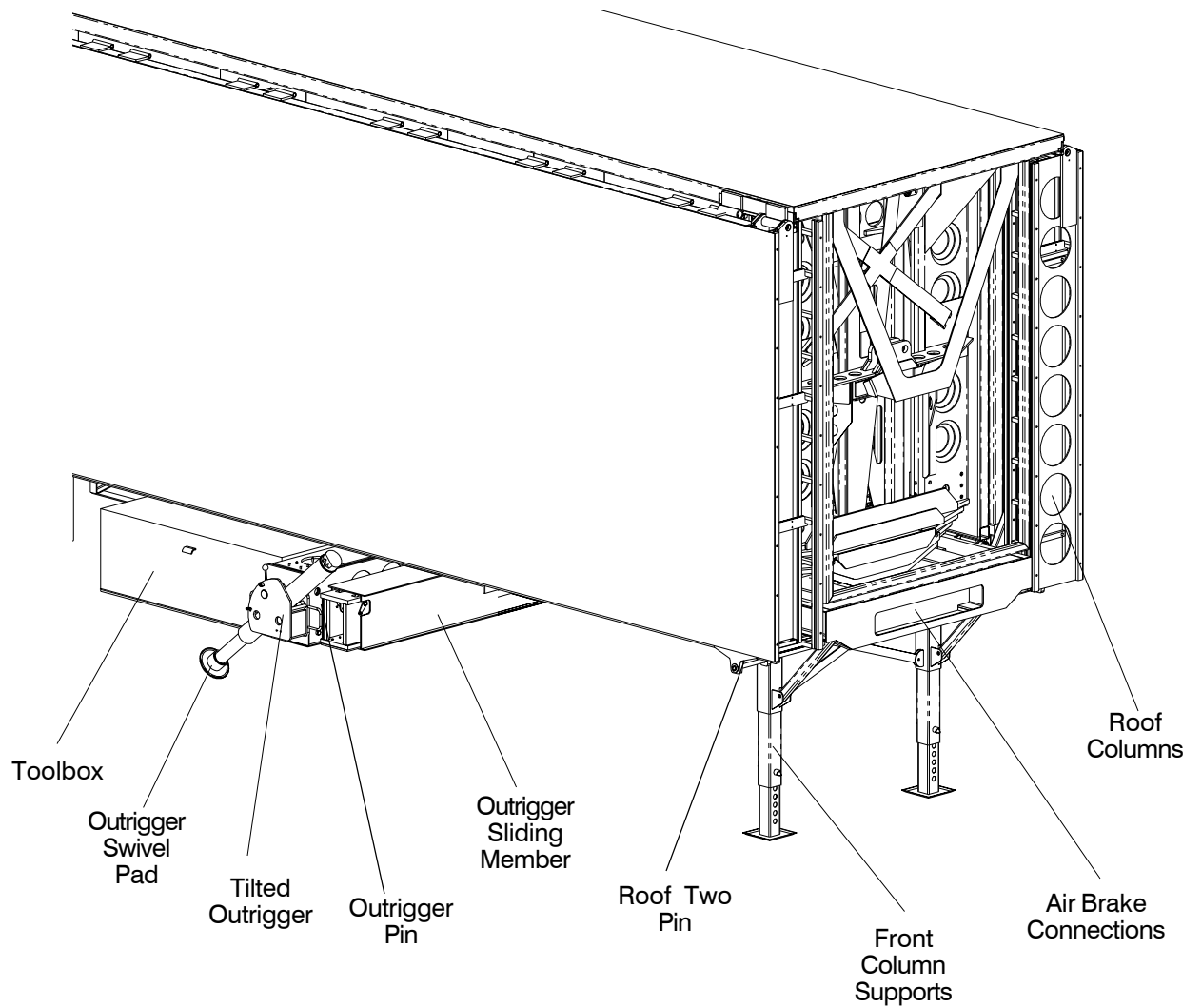

Front View, Stowed for Travel

Section 3 — Safety

Safety Procedures

Throughout this manual potential hazards are identified to inform personnel of situations that can be dangerous. It is imperative that personnel know the location of controls and their respective direction and operation, so they can act quickly in the event of an emergency.



It is not possible to identify all potential set-up conditions of the stage. The operator bears ultimate responsibility for following all regulations and safety rules of their employer and/or any state or federal law.

The best hedge against accidents is knowledge of the operation of the stage. The information contained in this manual needs to be read and fully understood by the operator.

General Operating Information

- Be aware of the surroundings.
- Inspect the stage before beginning the deployment process or before lowering and preparation for travel.
- Properly position the stage with the tractor before beginning the set-up process.
- Always operate the controls smoothly, avoiding sudden starts and stops.
- Never apply loads to the roof trusses prior to placing the roof in position.

Capacity

The floor of the stage is rated to hold 150 pounds per square foot. The capacity of the roof trusses vary depending on where the load is located and how the towers are pinned.

The load chart for the roof trusses and the pinning diagrams must be understood and followed (refer to the Capacity Diagrams). Under no conditions should these loads be exceeded.



Pinning of the towers is required before application of loads to the roof. The load conditions identified in the load chart are for specific locations on the trusses and must not be exceeded.

The load to be applied to the roof trusses must be calculated and the appropriate locations determined. The load capacity of the beam is identified as having the load distributed in one of four conditions:

- Uniformly
- Quarter Point
- Third Point
- Half Point

Loads need to be located uniformly, or at quarter points (quarter points) along the beam, or at third points (third points) along the beam, or in the center of the beam (half point).

At no time should this stage be used for lifting either materials or personnel.

SPEAKER WING LOAD CHART

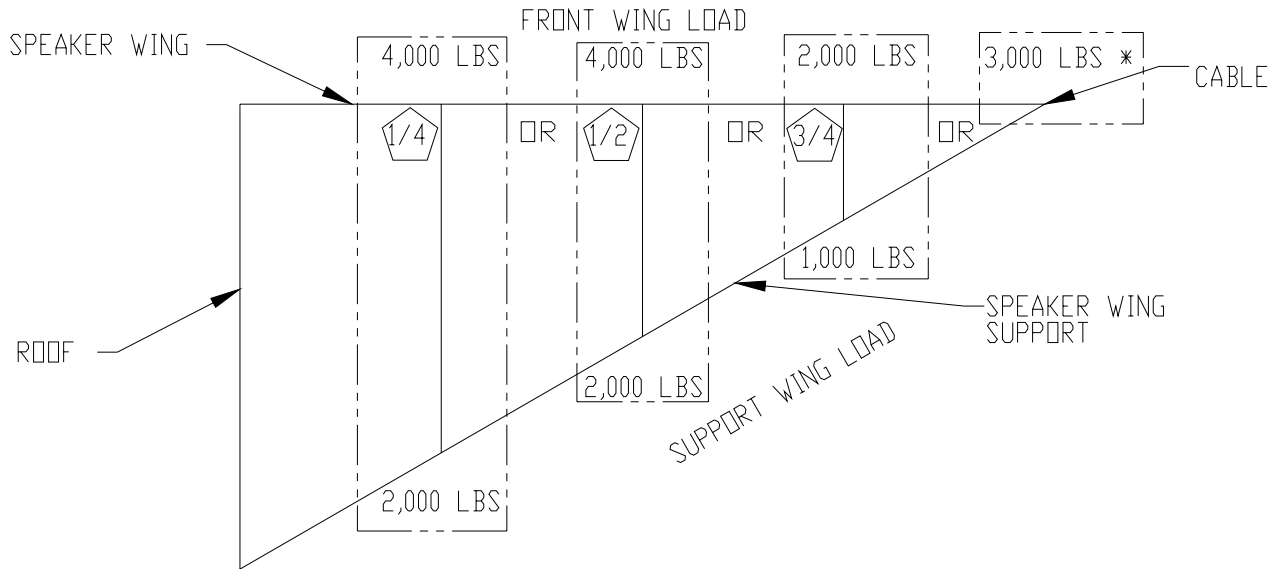

NOTES:

1. ONLY ONE LOADING CONDITION MAY BE APPLIED TO THE BEAM AT A TIME.
2. *END POINT LOAD IS ON FRONT WING NOT THE SUPPORT WING.

LIFT TOWER PINNING CHART

STAGE NUMBER	CEILING LOAD		
	32,334 LBS	22,334 LBS	12,334 LBS
1	N/A	N/A	N/A
2	PIN	PIN	PIN
3	PIN	PIN	PIN
4	PIN	PIN	PIN
5	PIN	PIN	PIN
6	NO PIN	NO PIN	NO PIN

NOTE: THIS CHART APPLIES TO ALL SET UP HEIGHTS.

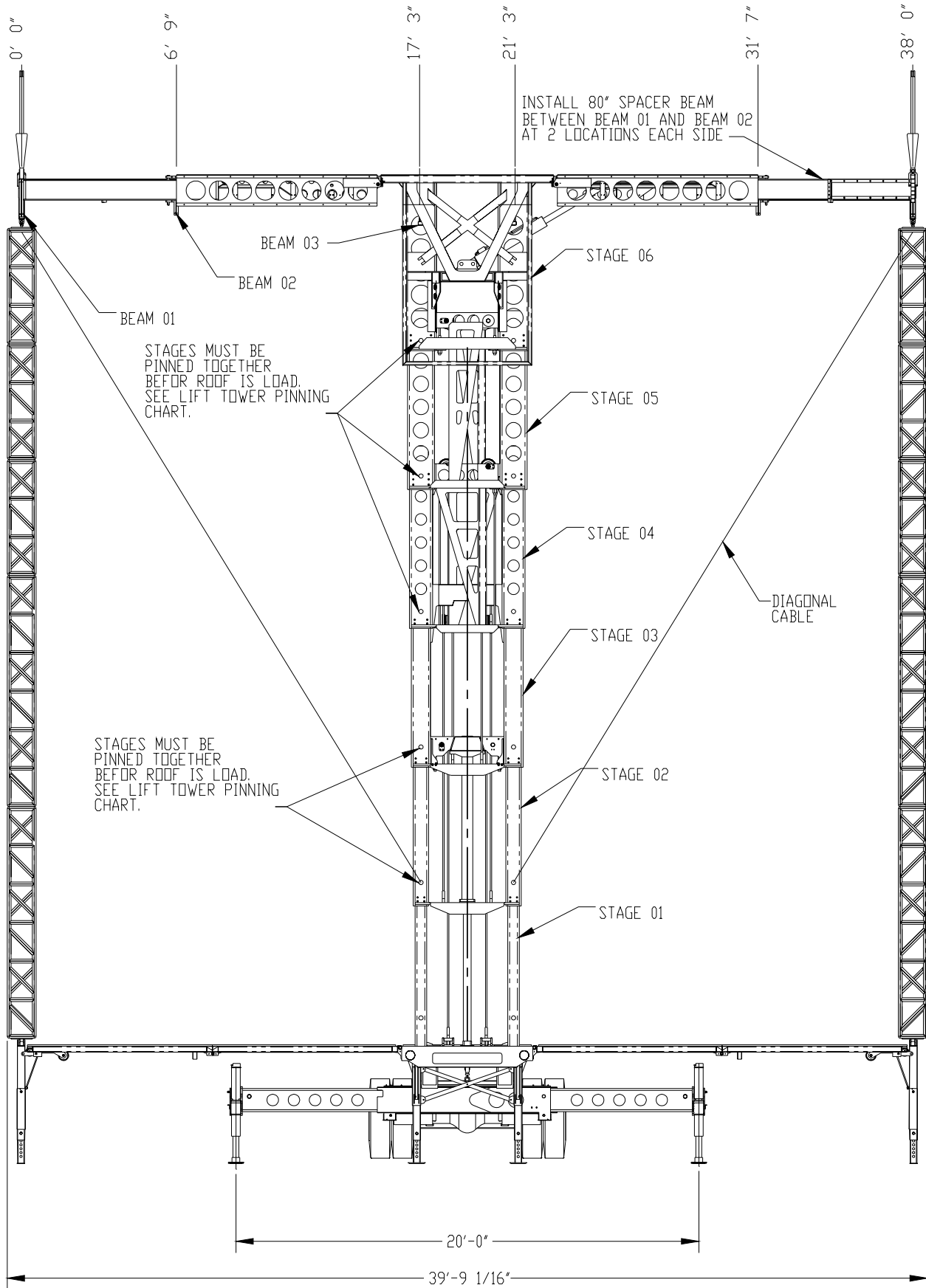

Section 4 — Before You Operate...

Operators involved in the deployment and care of this stage must know the location of controls identified in the component identification diagram and their respective direction and operation identified in Section 5 before operating the stage.

Stability

At no time should this stage be used for lifting either materials or personnel.

Throughout this manual potential hazards are identified to inform personnel of situations that can be dangerous. It is imperative that personnel know the location of controls and their respective direction and operation, so they can act quickly in the event of an emergency.

Danger

It is not possible to identify all potential set-up conditions of the stage. The operator bears ultimate responsibility for following all regulations and safety rules of their employer and/or any state or federal law.

Warning

Park on a firm surface before operating the unit. Always use parking brakes and wheel chocks. Outriggers must be extended as instructed under Outriggers.

It is not possible to identify all potential set-up conditions of the stage. The stage must be set-up and leveled on a firm surface with clear space overhead. The owner and operator bears ultimate responsibility for selection of a safe site and for properly setting up the stage. It is the operator's responsibility to following all regulations and safety rules of their employer and/or any state or federal law.

Warning

Untrained personnel can not be allowed to operate this stage.

Trained personnel must fully understand the stability of this stage before placing the stage and before deployment.

Attention

Welds and materials can fatigue and fail if the equipment is not used properly and operated smoothly.

The stability of the stage depends upon selecting a proper site for the stage with a firm footing. After locating the stage/trailer with the tractor to the final location, place the

tractor in neutral, set the parking brake, chock the tires of the stage/trailer. The stage is equipped with out and down outriggers to help stabilize the stage during deployment and after set-up is complete.

Caution

Always operate the controls smoothly, avoiding sudden starts and stops.

Avoid Energized Conductors

Danger

It is not possible to identify all potential set-up conditions of the stage. The operator bears ultimate responsibility for following all regulations and safety rules of their employer and/or any state or federal law.

During site inspection, observe the overhead space available of the deployment of this stage. The overall height of the fully deployed stage is approximately 45 feet.

Personnel are in danger if there are energized overhead conductors above the deployed stage. The operator bears ultimate responsibility for following all regulations and safety rules of their employer and/or any state or federal law.

Pre-operational Inspection

Inspection of the stage after each deployment or prior to delivery to a new venue is necessary for safe operation of the stage.

1. Position the stage/trailer on a level surface and check the hydraulic oil level in the site gauge. If the level is low add the appropriate hydraulic fluid until the tank is full. If the level of the oil is repeatedly low, a hydraulic leak is indicated and the stage should be inspected for leaks and they should be repaired.

Caution

When getting on or off the stage, use the provided stairs or other OSHA approved device. Be aware that hydraulic leaks or spills can cause slick surfaces.

2. Visually inspect the stage. Inspect pins, fasteners, cables, and welds for looseness or damage. Check hydraulic cylinders, hoses, and fittings for leakage or damage. Repair or replace any loose, damaged or defective components before operating the stage. Special attention should be given to the following components.

Pre-Operational Inspection Diagram

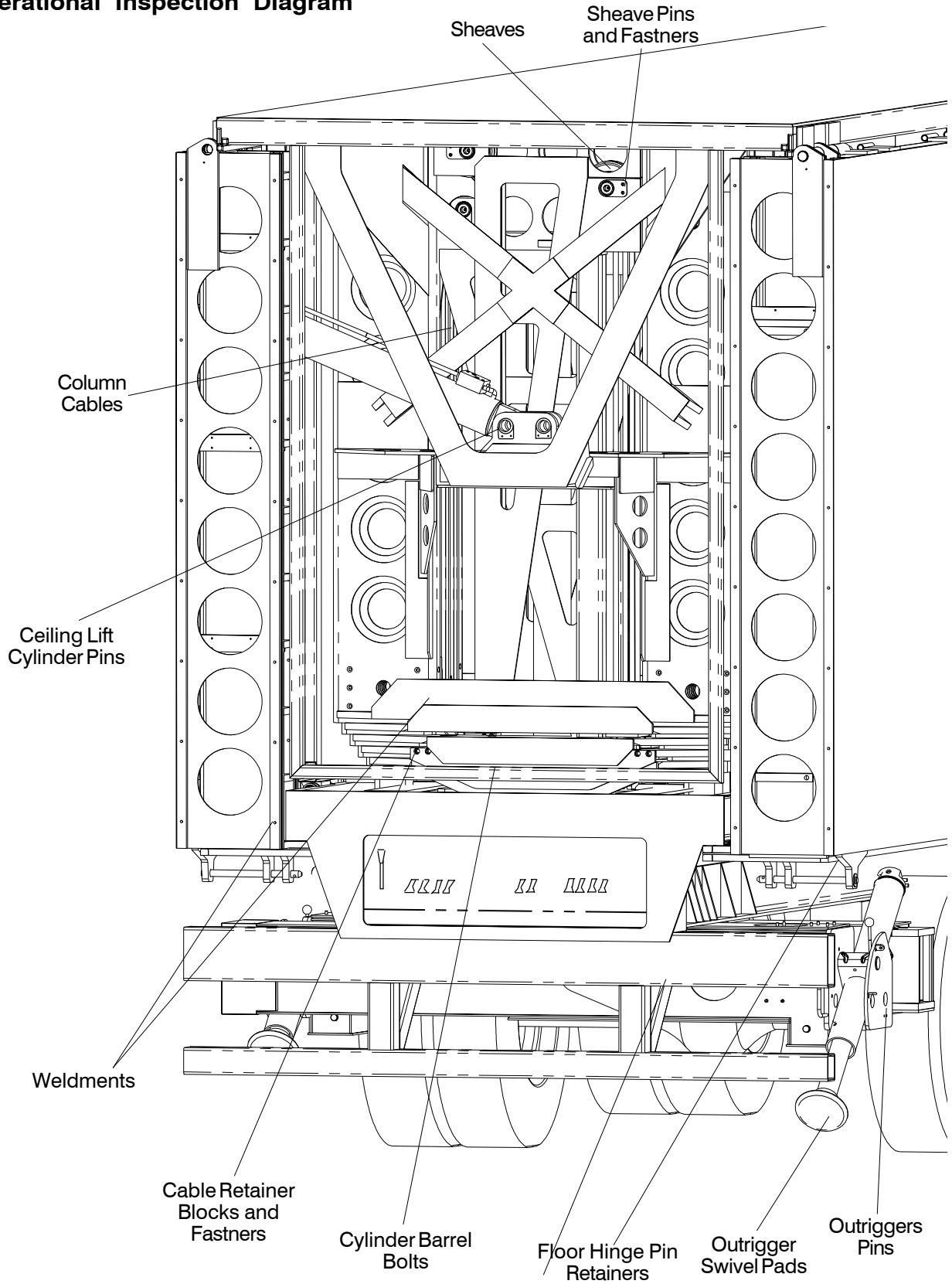

This diagram is for representational purposes only.
The operator bears ultimate responsibility for properly inspecting all components.

- Outrigger tilt levers
- Column cylinder mounting bolts
- Outrigger swivel pad bolts
- Roof lift cylinder mounting pins
- Floor lift cylinder mounting pins
- Floor hinge pin retainers
- Column Cables
- Column Cable Retainers
- Column Cable Fasteners
- Column Sheaves
- Column Sheave Pins
- Ceiling Lift Pins

3. Properly set the outriggers using the procedure detailed in Section 5 of this manual. Check for proper operation of the outriggers and for any leakage around the fittings or the outrigger legs. If any problems are identified, or and oil leak is identified, they must be repaired before deployment of the stage.



Caution

Always operate the outrigger smoothly, sudden movement can cause damage to the stage.

4. Operate the columns and inspect for hydraulic leaks while the tower is moving. If any problems are identified, or and oil leak is identified, they must be repaired before deployment of the stage.
5. Operate the floors and inspect for hydraulic leaks while the floor is moving. If any problems are identified, or and oil leak is identified, they must be repaired before deployment of the stage.
5. Operate the roofs and inspect for hydraulic leaks while the tower is moving. If any problems are identified, or and oil leak is identified, they must be repaired before deployment of the stage.

Preparation for Operation

1. Plan for the location of the stage and position the stage with the trailer to take advantage of the most level terrain while still landing the stage in its final location. Be mindful that the outriggers can be used to level the stage on slopes up to 7 degrees.



Danger

It is not possible to identify all potential set-up conditions of the stage. The stage must be set-up and leveled on a firm surface with clear space overhead. The owner and operator bears ultimate responsibility for selection of a safe site and for properly setting up the stage. It is the operator's responsibility to following all regulations and safety rules of their employer and/or any state or federal law.

2. After locating the stage/trailer with the tractor to the final location for the stage, place the tractor in neutral, set the parking brake, chock the tires of the stage/trailer.
3. Perform the daily pre-operational inspection defined earlier in the section.
4. Start the hydraulic engine and use the front outriggers to take the pressure off the kingpin.



Warning

During travel, the roof panels are stored below the kingpin plate. The tractor must pull out and back in straight with the trailer. Use the front outriggers to raise the stage for clearance if pulling out straight is not possible



Warning

Carefully pull the tractor away from the trailer. Sudden movement of the trailer will cause the kingpin plate to bang the front of the trailer and may damage the stage.

5. Disconnect the air hoses and electrical connections to the trailer and remove the tractor.

Cold Weather Operation

In order to operate the hydraulic system in temperatures of 32 degrees Fahrenheit or below, the hydraulic system should be filled with low temperature hydraulic oil.



Warning

Do not use additives in the hydraulic system, they can to wear or deterioration of the hydraulic components.

Attention

The hydraulic pump and oil system must be warmed before operation of the stage.

Start the engine and allow the hydraulic fluid to circulate through the valves and back to the tank until the fluid is warmed. Cold hydraulic can cause erratic or sudden movement upon operation of the controls.

Section 5 — Operation

The 50 foot by 38 foot StagePro Hydraulic Stage consists of a complex set of hydraulically operated systems that must be operated in a proper sequence. This section will address the operation of each hydraulic system.

Before operation of this stage, the operator must become familiar with the stage and its capabilities. Operator training by an authorized representative of StagePro is a requirement for operation of this equipment.

This stage is equipped with outriggers for stability. Before operating the stage, perform the Pre-Operational inspection detailed in Section 4.

Danger

It is not possible to identify all potential set-up conditions of the stage. The operator bears ultimate responsibility for following all regulations and safety rules of their employer and/or any state or federal law.

Warning

Park on a firm surface before operating the unit. Always use parking brakes and wheel chocks. Outriggers must be extended as instructed under Outriggers.

It is not possible to identify all potential set-up conditions of the stage. The stage must be set-up and leveled on a firm surface with clear space overhead. The owner and operator bears ultimate responsibility for selection of a safe site and for properly setting up the stage. It is the operator's responsibility to following all regulations and safety rules of their employer and/or any state or federal law.

Hydraulic Controls

Stability for the stage is provided with out and down outriggers. Figure 5.1 shows the controls located at the



Figure 5.1 — Outrigger Controls

back of the stage/trailer. These hydraulic controls are manual valves that can be metered by limiting the travel of the lever handle. Moving the valve to the full extent in one direction provides full on supply of hydraulic fluid to the cylinder being controlled. Moving the valve a partial distance meters the flow to that same cylinder.

From these valves control is provided for the outriggers, the floor deployment cylinders, the column cylinder and the roof lift cylinders. In addition a lever operated switch is moved to control the flow of the hydraulic fluid to either the outriggers or the stage deployment functions.

Outriggers

To direct fluid flow to the outriggers, the diverter lever must be pushed into the control panel (refer to Figure 5.2).

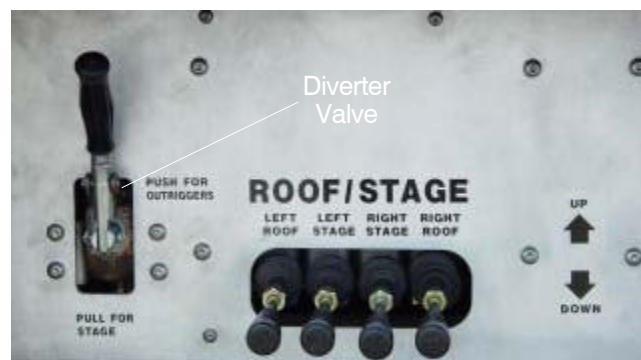

Figure 5.2 — Flow Diverter Valve

Once the diverter level is pushed in, the outrigger control handles will operate the outriggers. On lever is provided for each outrigger cylinder. Pressing down on the outrigger handle lowers the stage and raising up on the handle raises the stage (refer to figure 5.3). The following procedure is used to set the outriggers.



Figure 5.3 — Outrigger Control Handles

Danger

It is not possible to identify all potential set-up conditions of the stage. The operator bears ultimate responsibility for following all regulations and safety rules of their employer and/or any state or federal law.

1. The stage/trailer must be positioned to the exact location of the stage setting with the tractor. There are no provisions for moving the stage after it is released from the tractor.

Warning

Park on a firm surface before operating the unit. Always use parking brakes and wheel chocks. Outriggers must be extended as instructed under Outriggers.

It is not possible to identify all potential set-up conditions of the stage. The stage must be set-up and leveled on a firm surface with clear space overhead. The owner and operator bears ultimate responsibility for selection of a safe site and for properly setting up the stage. It is the operator's responsibility to following all regulations and safety rules of their employer and/or any state or federal law.

- Start the hydraulic engine and deploy the front outriggers to take the pressure off the kingpin.

Warning

During travel, the roof panels are stored below the kingpin plate. The tractor must pull out, and back in, straight with the trailer. Use the front outriggers to raise the stage for clearance if pulling out straight is not possible.

Warning

Carefully pull the tractor away from the trailer. Sudden movement of the trailer will cause the kingpin plate to bang the front of the trailer and may damage the stage.

- Disconnect the air hoses and electrical connections to the trailer and remove the tractor.
2. The outriggers are to be deployed and pinned in position at all four locations.
 - Using the outrigger tilt levers, take a firm grip on the top of the outrigger, release the tilt control pins with the lever, position the outriggers to vertical, and engage the pins with the levers. Spring tension will cause the pins to protrude. Make certain pins are full engaged and lock the pins in place with the provided retainer pins (refer to Figure 5.4).

- Outrigger pads are to be placed under each outrigger. No single outrigger is to be setting on a slope greater than 7 degrees. In the event that the slope exceeds 7 degrees, then the pad must be leveled before deployment of the outriggers.

Warning

This stage is designed to operate only when leveled. The outriggers must be positioned on firm ground and the stage/trailer leveled before deployment of the stage.

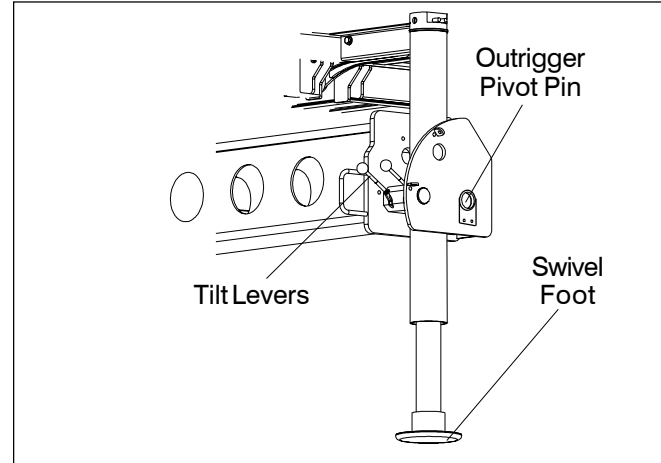

Figure 5.4 — Vertical Outriggers

Warning

The outrigger swivel feet must rest on a firm surface and cannot be allowed to bridge gaps. Outrigger pads should be used beneath the outriggers.

3. During travel the roof trusses are folded underneath the floor of the trailer. For access to the front column supports, move the roof panels out following the procedures below:
 - Remove the electrical connection between the roof and floor sections.
 - The hydraulic control levers shown on the left in Figure 5.5 are used to tilt the roof.



Figure 5.5 — Roof Raise and Tilt Controls

Caution

Always operate the controls smoothly, avoiding sudden starts and stops.

- Tilt the roof sections away from the trailer until they are well away from the floor (approximately 20 degrees from vertical travel position).



Warning
During travel the roof trusses are folded underneath the floor of the trailer. Failure to tilt the roofs out before deploying the outriggers will result in damage to the structures.

4. Level the trailer by first raising the stage with the outriggers on the lower side of the trailer. Then add the high side outriggers and level the trailer.
5. Use a 48 inch carpenter's level and level the side to side slope of the stage by placing the level across the back of the stage above the control panel. Use the outriggers to adjust the slope until it is level.
6. Repeat this procedure for the front of the trailer.
7. Once again use a 48 inch carpenter's level and level the front to back slope of the stage by placing the level along the trailer beam beneath the stage. Use the outriggers to adjust the slope until the trailer is level front to back.
8. Repeat Steps 6 thru 9 until all of the tires are raised completely off the ground, the height of the stage is set, and the stage is level both side to side and front to back.
9. Remove the adjustable corner supports from the tool box and position one support under each column. Fasten in place with the provided pins (refer to Figure 5.6).

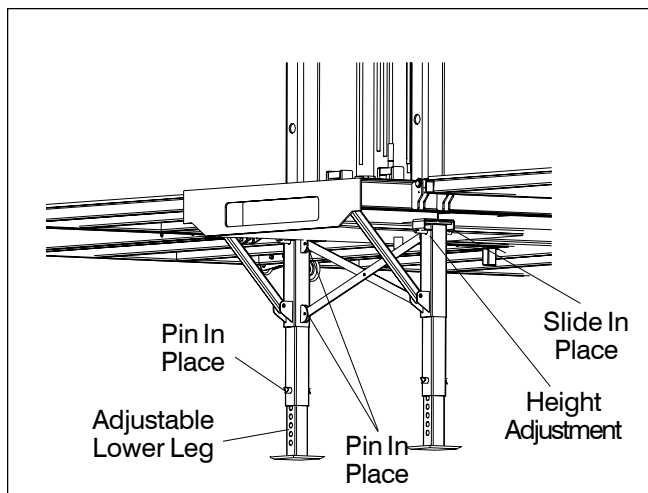

Figure 5.6— Front Column Supports

10. Release the lower leg pin and adjust the leg to the lowest setting and replace the pin. Using the carpenter's level, turn the adjustment nut until the stage is leveled.

Floor Roller Guides

Before lowering the floor it is necessary to raise the roof system approximately 12 inches and tilt each Roof One section out to a 45 degree angle. Refer to the paragraph on raising and deploying the roof later in this section for detailed instructions on completing this task.

With the outriggers properly set and the roof move up and out of the way, unpin, position and level the floor roller supports. These support are to be position under the rollers that protrude down from the floor and raised up against the trailer frame rails until the support is at the top of the hinge bracket. Using a 48 inch carpenter's level, level the support at all four locations (refer to Figure 5.7).

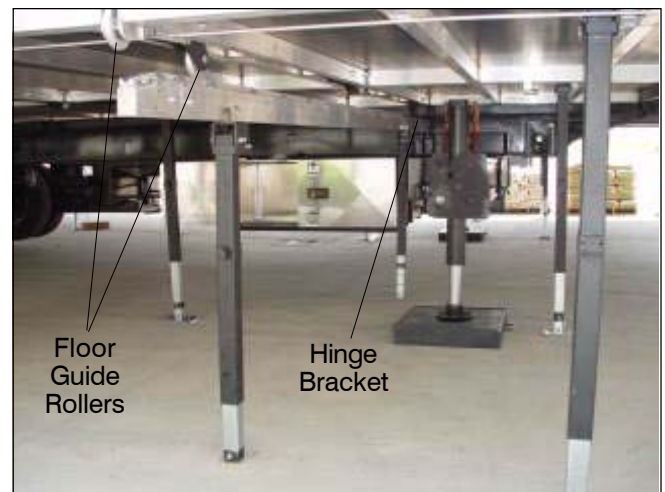

Figure 5.7 — Floor Roller Supports

Lowering the Floor

With the floor supports in position, use the hydraulic controls to lower the floor onto the floor supports.



Always operate the controls smoothly, avoiding sudden starts and stops.

Gently move the hydraulic lever until the floor guide rollers are a few inches above the supports (refer to Figure 5.2). Next pull the outer edge of the floor out from the trailer and gently lower the floor into the support.



Make certain the floor edge clears the outrigger cylinders.

Once the floor has made contact with the support, proceed with lowering the floor until it rests on the support. Firmly hold down the hydraulic lever until all of the floor cylinders have completely lowered the floor. This is used to re-sequence the cylinders and is necessary for their operation when raising the floor during closure. Repeat this procedure for the floor on the opposite side.

Corner Supports

Remove the adjustable corner supports from the tool box and position one support under each corner. Fasten in place with one bolt and the provided pins (refer to Figure 5.8).

This support provides support for the corner of the stage and also supports the vertical column that will be attached directly to this support after Roof Two is deployed.

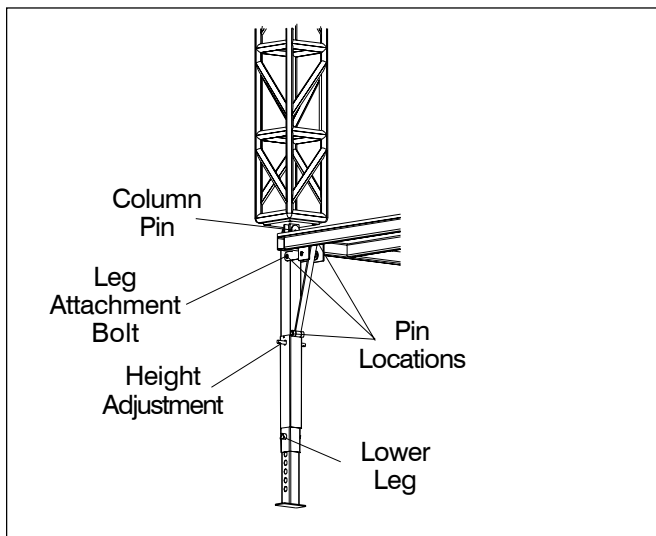

Figure 5.8 — Corner Supports

Floor Supports

Located under the stage floor and attached to the floor are 12 floor leveling jacks (refer to Figure 5.9).

Unpin the lower leg of each jack and extend the lower leg. Re-pin the lower leg and adjust the floor using the screw adjustment located on the side of the jack. Repeat this procedure for each jack until both floors are level.

Raising and Tilting the Roof

With the outriggers properly set, the roof can be raised into position.



Warning

During travel the roof trusses are folded underneath the floor of the trailer. Failure to tilt the roofs out before raising the roof will result in damage to the structures.



Figure 5.9— Floor Supports

Move the valve handles gently and tilt the roof sections away from the trailer until they are well clear of the trailer (refer to Figure 5.10)



Figure 5.10 — Roof Raise and Tilt Controls

The hydraulic control lever shown in Figure 5.10 are used to lift the roof. One lever controls the front set of columns and a second lever controls the rear set of columns.



Caution

Always operate the controls smoothly, avoiding sudden starts and stops.

It is imperative that the front and rear column heights are kept equal in height during the raising of the roof.

Gently move the hydraulic lever until the column begins to move up. Because of the cable lift system, each column moves the same amount simultaneously. When the second column section is lifted 2 inches with the hydraulic cylinder, each section is lifted 2 inches and thus the overall height of the stage is increased by 10 inches. Thus slight variations in the lift by the cylinder will cause great unevenness on the roof.

For deployment of the floor the columns need to be raised approximately 12 inches per section and the roof sections need to be tilted using the procedure detailed later in this section.

The columns are equipped with pin holes for securing the columns once lifting is complete. There are two sets of pin holes located in the columns (refer to the Capacity Diagram on page 10). The lower set will provide a height from floor to the bottom of the center truss of 25 feet 4.5 inches, the second set will provide a distance of 35 feet 4.5 inches.

After the floor is leveled, the roof is ready to be deployed. The following procedure details the steps necessary for full deployment of the roof.

1. To slide Roof 2 out of Roof 1, first position resting pads (shaped 4x4's) on the stage floor adjacent to the towers and at each end of the roof.
2. Raise the roof with approximately one foot of cylinder travel.
3. Gently tilt one roof in toward the tower assembly until the lip of Truss 1 is approximately 6 inches from the base of the tower.
4. Lower the roof assembly until Roof 2 is setting on the resting pads in the coped 4 x 4's.
5. With Roof 2 resting on the 4 x 4's, remove the Roof 2 restraining pins from each end.
6. Raise the roof assembly slowly until Roof 2 is fully extended and then tilt Roof 1 upward until it is level.
7. Repeat this procedure for the other side.
8. Raise and tilt the roof to provide access to the corner of the roof for installation of the speaker bay supports.
9. Fold out the speaker bay trusses and secure in place by adding the diagonal truss. Pin the diagonal truss in place (refer to Figure 5.11).

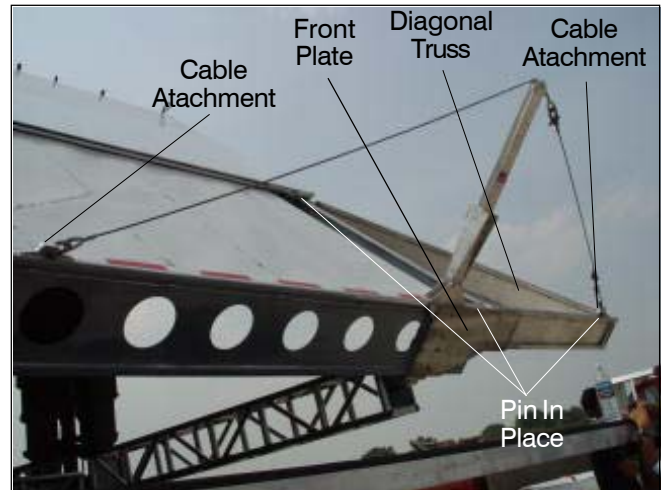

Figure 5.11 — Speaker Bays

10. Install the front support plate and bolt in place.
11. Add the cable and cable tower. Adjust the cable turnbuckle until the slack is removed from the cable.



The swivel connector must be oriented as shown in the Figure below to allow the pivot motion towards and away from the main columns.

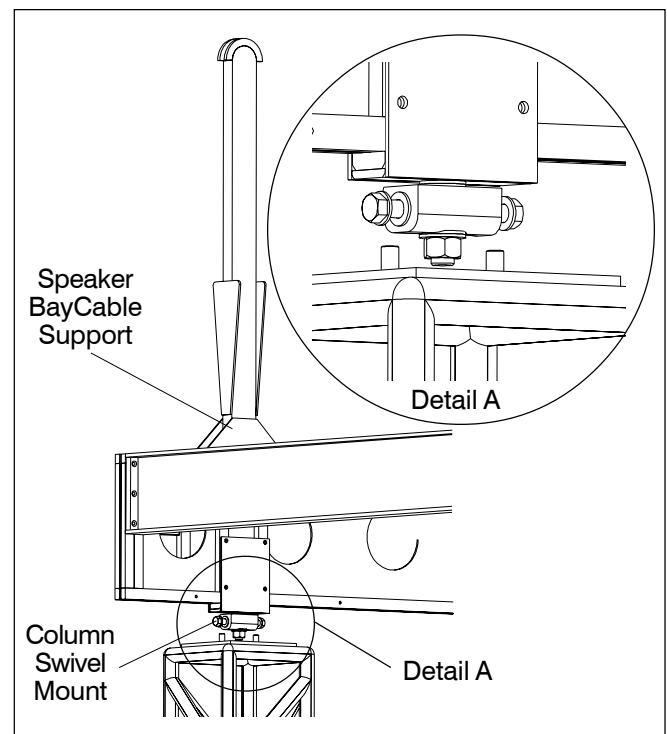

Figure 5.12 — Upper Column Attachment

12. Tilt one roof and attach a section of 10 foot of column truss to each roof corner with the swivel connector (refer to Figure 5.12).

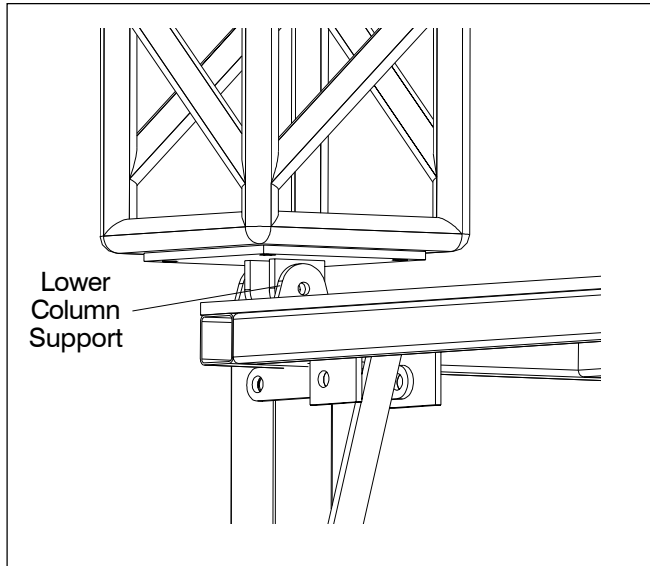

Figure 5.12 — Lower Column Attachment

13. Repeat this procedure for all four corners.

14. With all four columns attached to the corner swivels, raise the roof and attach additional corner sections as required for the set height of the stage.

15. Attach the base of the last column truss to the corner support (refer to Figure 5.12). It may be necessary to tilt the roof above level to align these holes.

16. After the column is supported adjust the tilt of the roof for a very slight slope toward the edge of the stage.

Section 6 — Care of the Unit

An alert stage operator can contribute to the care of the stage. The observation and correction of minor maintenance problems, as they occur, may prevent costly repairs and lengthy downtime, and improve safety.

At no time should a StagePro stage be altered or modified without specific written approval from StagePro, Inc.

Hydraulic System

The condition of the hydraulic oil is a major factor in obtaining long life and trouble-free service from the hydraulic system components. The oil temperature, level, and cleanliness must be properly maintained.

Attention

Do not put the stage in service and run the pump at normal operating speeds until the hydraulic oil reservoir feels warm to the touch.

The minimum temperature at which oil will flow to the pump varies with the type of oil in the reservoir. Regardless of the hydraulic oil used, improper start-up can quickly damage the pump. Always allow the oil to warm up before running the engine or pump at high speed. Section 4 under Cold Weather Start-Up describes this procedure.

The maximum temperature at which the hydraulic system can operate depends on the hydraulic oil used. Cold weather oil should not exceed 160 degrees Fahrenheit and warm weather oil should not exceed 180 degrees Fahrenheit.

If overheating occurs during normal use, identify the cause and have it corrected immediately.



Warning

Only use hydraulic oil as recommended. Other fluids added to the hydraulic system can increase component wear, affecting the lubricating characteristics of the oil.

Check the oil level in the hydraulic reservoir before each event. When checking the oil level the vehicle should be on level ground with the booms and outriggers stowed. The oil level must be within the acceptable range shown on the sight gage. If oil must be added, use the proper type as described in the Stage Specification Chart. Immediately report any unusual hydraulic system noise observed during operation so the cause can be identified and corrected.

Maintain the Unit

Report any unusual noises, loose fasteners, pins, pin retainers, etc., so the cause can be identified and corrected.



Caution

Keep the unit and work areas clean. Spilled hydraulic oil creates slick surfaces and can cause personnel to slip and/or fall.

Proper lubrication on a regular basis will increase the life of the stage and help to prevent maintenance problems.

Start and stop all operations as smoothly as possible. Do not allow debris, tools, etc., to accumulate on the stage.

When cleaning with high pressure washers or steam cleaning equipment, do not directly spray the electrical components, control valves, or cylinder seals. However, high pressure fluids can force their way past the seals and cause corrosion to start.

APEX 50 X0 38 HYDRAULIC STAGE

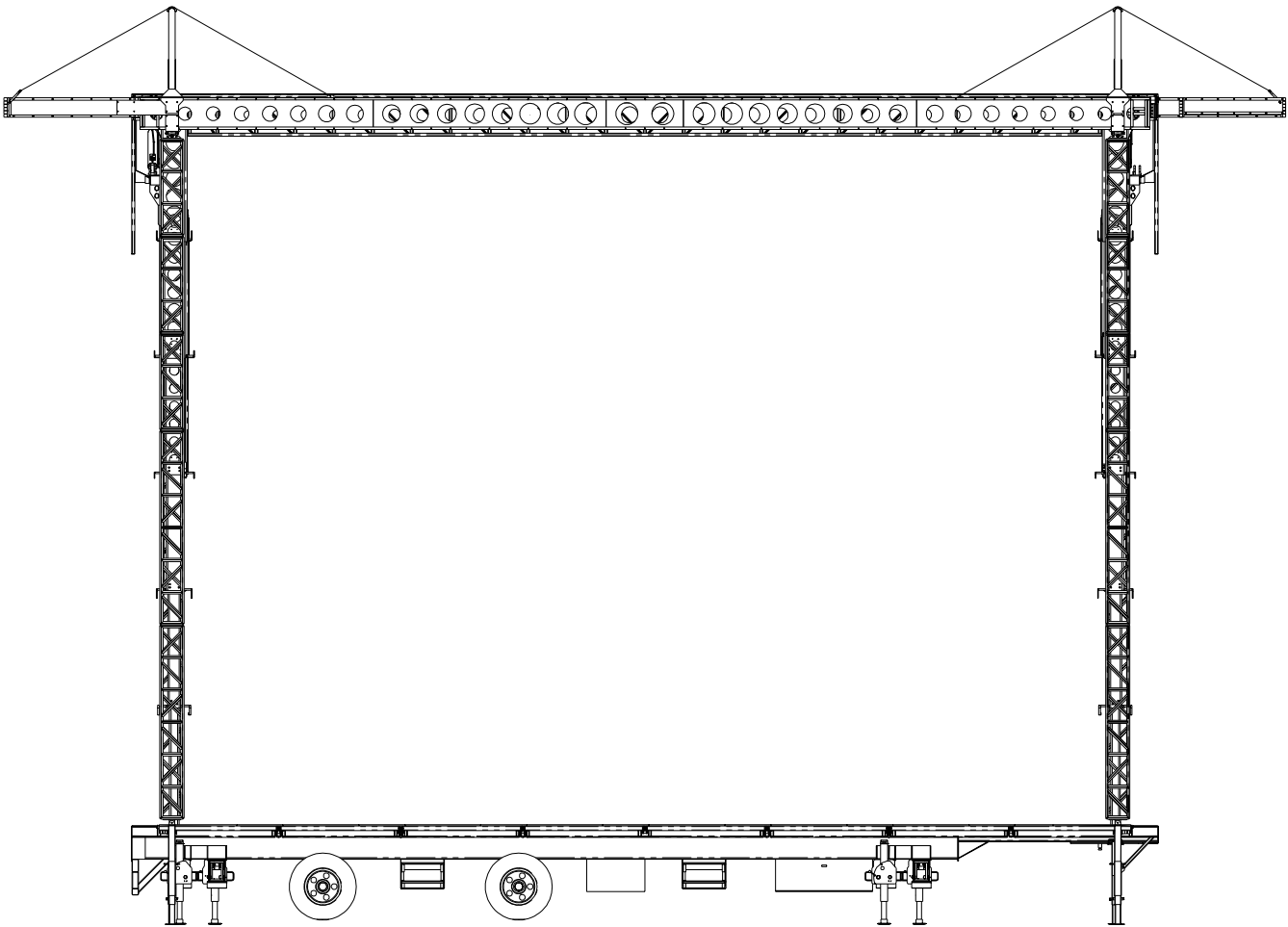

Operator's Manual

October 2005

Copyright 2005 by StagePro, Inc.

This manual is the sole property of StagePro. StagePro reserves the right to modify and make improvements to the design without and specifications without notice.

Table of Contents

Section 1 — Introduction

About This Manual	1
-------------------------	---

Section 2 — Unit Specifications

Purpose of the Stage	3
General Specifications	3
Component Identification	4

Section 3 — Safety

Safety Procedures	7
General Operating Information	7
Capacity	7
Capacity Diagrams	8

Section 4 — Before You Operate...

Stability	11
Avoid Energized Conductors	11
Pre-operational Inspection	11
Pre-Operational Inspection Diagram	12
Preparation for Operation	13
Cold Weather Operation	13

Section 5 — Operation

Hydraulic Controls	15
Outriggers	15
Floor Roller Guides	17
Lowering the Floor	17
Corner Supports	18
Floor Supports	18
Raising and Tilting the Roof	18

Section 6— Care of the Unit

Hydraulic System	21
Structures and Mechanical Systems	21